



MS846



**Main material and finish:** Black powder coated ZDC handle, housing; Zinc plated steel cam and drive bar; Bright chrome plated ZDC profile cylinder.

**Remarks:** Default TC01; Default Key K14; PA housing for selection, MOQ 200pcs.

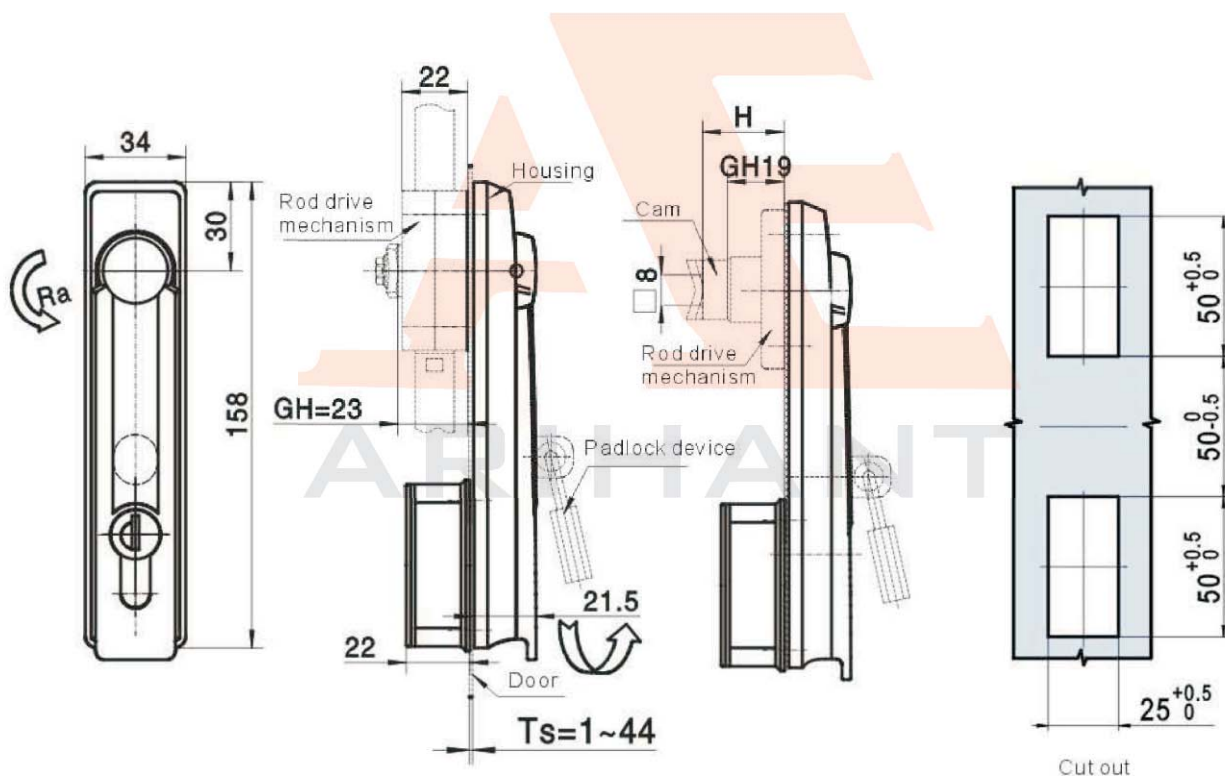

Accessories for selection: Mb9 (Rod drive mechanism by cam)P5-017  
Mb0 (Rod drive mechanism by bar)P5-017  
TC01/TC02/TC03

MS846-2-P	By cam, with padlock device
● MS846-2	By cam
MS846-1-2P	With Mb02 rod drive mechanism and padlock device
● MS846-1-2	With Mb02 rod drive mechanism
MS846-1-P	With Mb01 rod drive mechanism and padlock device
● MS846-1	With Mb01 rod drive mechanism
CODE	SPECIFICATION