

## MS324

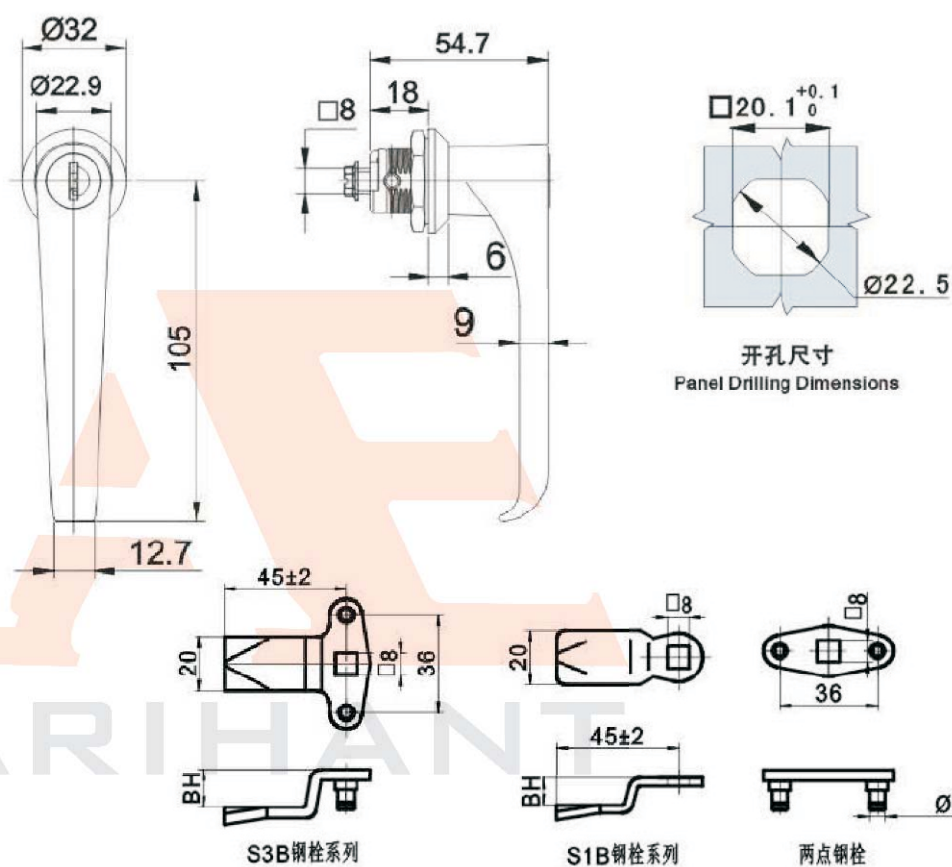

材质及表面处理: 黑色锌合金喷涂锁体, 镀锌钢栓。  
备注: 默认钥匙K16;

**Material and finish:** Black powder coated ZDC lock body, zinc-plated steel cam;

**Remarks:** Default key K16;

注: 默认钢栓S1B4507钢栓, 即 $H=19+7$ ;

钢栓开孔 $8 \times 8$ , 可选用三点、两点或单点钢栓, 详见钢栓列表;